



# WORKSWELL WIC SC SCIENCE THERMAL CAMERA

**Release date:** 6<sup>th</sup> of February 2021

**Revision Number:** 210206

# Workswell WIC SC for science applications

## Introduction

**Workswell WIC SC** are designed and manufactured for easy and user-friendly integration for R&D and Science applications as well as integration projects. All Workswell Infrared Cameras use the newest Long Wave Infrared Detector Technology. Customers can choose from three types of detector resolution: 640 x 512 and 336 x 256 pixel format.

**WIC SC is powered directly from USB3 or via PoE and Ethernet** cable. Internal electronics is protected by metal enclosure. Very low power consumption decreases needs for special cooling and large camera dimensions. WIC are fully compatible with USB3 and Gigabit Ethernet protocol.

Workswell CorePlayer software automatically detects a camera, configures an address and ensures a camera connection. **All WIC use 14 RAW data format or calculated calibrated temperature values.** Image can be shown in different color palletes with interactive side bar and measurement tools. Users can manage camera parameters such as Gain, NUC, Factory Reset, etc. There is also tutorial application, Linux and Windows dll libraries and C# application code available.

## Key Features

- Fully radiometric and calibrated
- 2x software CorePlayer integrated
- 2x exchangeable lenses in the package
- Linux x86 and Windows SDK in the package
- ARM SDK included in the package
- 30mK sensitivity in standard
- USB3 or 1Gb/s Ethernet interface
- LWIR 640 px and 336 px detector
- 4-side tripod and metric threads
- IP65 protection kit in the package
- Temperature range up to 1 500 °C (2 732 °F)
- Different types of lenses
- Up to fast 60 Hz camera versions

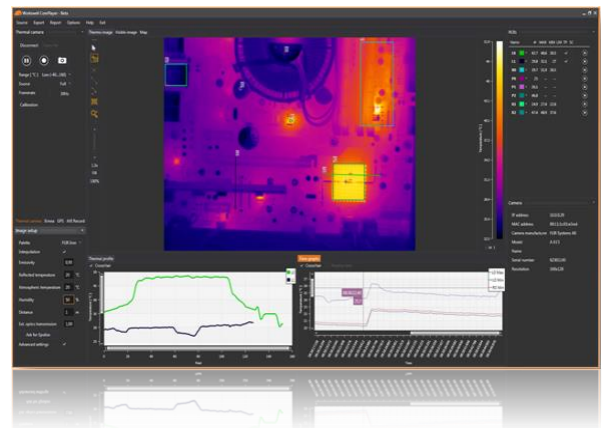

# Workswell WIC SC specification

Thermal and optical data	
Resolution	640 x 512 pixels and 336 x 256 pixels
Framerate	60Hz, 30 Hz or <9 Hz available
Temperature ranges	-25 °C to +150 °C (-13 °F to 302 °F) -40 °C to +550 °C (-40 °F to 1 022 °F) optional temperature range +50 – 1 000 °C (122 °F to 1 832 °F) optional temperature range +400 – 1 500 °C (752 °F to 2 732 °F)
Accuracy	±2 % or ±2 °C (±3.6 °F) (in temperature range -10 °C to +150 °C (-13 °F to 302 °F) and 0 °C to +550°C (-40 °F to 1 022 °F))
Temperature sensitivity	≤0.03°C (30mK) @ 30°C
Spectral Range	7.5 – 13.5 μm
Dynamic range	14bit radiometric temperature data, 14bit RAW data
Calibration	Yes, calibrated both temperature ranges
Detector Type	Uncooled VOx microbolometer
Lenses	2 lenses in the package, interchangeable and focusable, various field of view
Available Lenses	6.8mm, 9mm, 13mm, 19mm (more information in <a href="#">FOV calculator</a> )
Focus	Manual continuous (Min. focus distance depends on lens)
Linux ARM distribution and devices	More information: <a href="https://software.workswell.eu/wic_sdk/ARM/doc/">https://software.workswell.eu/wic_sdk/ARM/doc/</a>
Communication and Power Supply Interface	
Ethernet version	Gigabit Ethernet, RJ-45 connector
USB3 version	USB3, Thumbscrews lock micro USB connector
Analog video output	PAL/NTSC video format (only for USB3 version)
Input Supply Voltage	5 V DC for USB3, Power over Ethernet 48V type
Power Dissipation	< 1.3 W (max. 3 W during NUC calibration time)
Mechanical data	
Dimensions for USB3 version	97 x 65 x 63 mm for IP40 for WFOV, 186 x 65 x 63 mm for IP65 for WFOV,
Dimensions for GIGE version	106 x 65 x 63 mm for IP40 for WFOV, 179 x 65 x 63 mm for IP65 for WFOV,
Weight	360 g for GIGE WFOV model (without back IP65 cover)
Mounting and tripod	4 x 1/4-20 UNC thread and 10 x M4
Internal Protection	IP65 with IP protection kit



# Workswell WIC SC specification

Operating Environment	
Operating temperature	-15 °C to +50 °C (5 °F to 122 °F)
Storage temperature	-30 °C to +60 °C (-22 °F to 140 °F)
Humidity	5% to 95% non-condensing
Content of delivery	Workswell WIC SC, 2x lenses, IP65 protection kit, Linux x86 and Windows SDK, ARM SDK, 2x desktop software, calibration certificate, PoE (GigE version), cables, download card, hard transport case
Thermal Camera Settings	
Source of image	As a source of image can be used <b>full image</b> (full sensor size) or only a part of the image specified by a rectangle <b>ROI</b> tool
Framerate	According to the camera you can change frame-rate from <b>1Hz to 60Hz</b>
Calibration	Using <b>Calibration</b> button you can activate <b>NUC</b> (non-uniformity compensation) to reach the best image quality and camera signal stabilization
Play/Pause	Using Play/Pause icon you can start and pause real time image streaming
Start recording/Snapshot	During radiometric thermal video acquisition (using <b>Start capture</b> button) you can save <b>snapshots</b> (Radiometric JPG) at the same time
AVI Record	User can save live video streaming directly as <b>AVI format</b> . It is possible to change framerate and bitrate and display into the video <b>Palette bar</b> , <b>Bottom bar</b> and <b>ROI</b>
Thermal Image Settings	
Palette	User can choose from <b>14 palettes</b> – BlackRed, BlueRed, BWRGB, Fire, FLIR Iron, Gradient, Gray, Iron1, Natural, Rainbow, Sepia, Steps, Temperature, WBRGB
Interpolation	To obtain a smooth image without pixelization, user can interpolate the image
Units	Temperature can be displayed and calculated in <b>°C or °F</b>
Acquisition Parameters	<b>Emissivity</b> (continuously in range 0.01 – 1.0 with step 0,01) and <b>Reflected temperature</b>
Advanced Parameters	In CorePlayer can be set/changed other parameters as <b>Atmospheric temperature</b> , <b>Humidity</b> , <b>Distance</b> and <b>Transmission of external optics</b>
Temperature Range	Interactive temperature range can be used in <b>manual</b> or <b>automatic</b> mode. Using it you can change the color distribution of temperatures to e.g. highlight details.
Isothermal Mode	User can set <b>Isothermal mode</b> of the image. CorePlayer offers four types of isotherms: <b>Below</b> , <b>Above</b> , <b>Between</b> and <b>Below and Above</b> .
Report generation	
Report Contents	There are automatically shown <b>thermal images</b> and <b>time graphs</b> and parameters of the image: <b>emissivity</b> , <b>reflected temperature</b> , <b>atmospheric temperature</b> , <b>humidity</b> , <b>distance</b> and <b>transmission of external optics</b>
Additional Information	User can insert into a report: <b>protocol name</b> , <b>date and time</b> of measurement, company <b>logo</b> , <b>user/company name</b> and additional information about measured <b>area</b>



# Workswell WIC SC specification

Measurement features	
ROI analysis	User can insert into the image variety of measurement tools/ROI: <b>Point, Line, Polyline</b> and <b>Rectangle</b> . User can insert more ROIs into one image, change its color, replace it or delete ROIs that a user can see in the top-right subwindow
Zoom	User can <b>zoom</b> real-time streamed data, the acquired image or sequence – continuously, each mouse scroll zooms 0,5x
Measured Values	In each ROI can be measured and visualized <b>Min, Max, and Average</b> temperature. User can save temperature values from the ROI as <b>CSV file</b>
Graphs	
Thermal Scanner	Temperature values for Line ROI could be visualized in <b>Thermal Scanner</b> . User can select number of lines and temperature range (manual or automatic)
Thermal Profile	All measured data can be displayed in real time <b>Thermal Profile</b> (for Line ROI). User can adjust range of <b>graph axis</b> and see the measurement <b>Target Cross</b> for fast and easy visualization of measured graph values
Time Graph	Temperature values from all ROI tools (for real time visualization or captured sequence measurement) can be showed into the <b>Time Graph</b> . User can adjust range of <b>graph axis</b> and see the measurement <b>Target Cross</b> for fast and easy visualization of graph values. For saved sequence can be set upper and lower <b>limit</b> for the temperatures in each ROI and x-axis in <b>relative or real time</b>
Radiometric Sequence	
Playback	Radiometric video can be played <b>Backwards, Forwards</b> , show <b>Next frame</b> or <b>Previous frame</b> or play the sequence continuously in the <b>loop</b>
Processing	User can <b>cut</b> the video and save it into new file as radiometric sequence.
Additional functions	
Export	User can export images into different file formats - save <b>*.seq</b> file as <b>Radiometric JPEG, PNG</b> or <b>CSV</b> file. Radiometric sequence can be exported to <b>AVI</b> file
Presentation Mode	For presentation purposes the live stream or acquired image can be displayed in <b>full screen mode</b> with image related controls.
User Interface	Intuitive and well-arranged <b>user interface</b> . User can change layout of sub-windows or restore layout to defaults
Image Information	The information about saved image in sub-window: <b>filename, camera type, captured date, resolution, emissivity and reflected temperature</b>
Camera Information	CorePlayer shows information about connected camera: <b>IP and MAC address, Camera manufacturer, Camera model, Name, Serial number</b> and <b>Resolution</b>
GPS Support	CorePlayer supports integration of <b>GPS data</b> from standard GPS receiver and display the position in Google Maps



## Workswell WIC SC lenses

Resolution 640 x 512 pixels	Field of view	Spatial resolution IFOV	Min focus distance
Focal length 9 mm	FOV 69° x 56°	1.889 mrad from 1 meter	7 cm
Focal length 13 mm	FOV 45° x 37°	1.308 mrad from 1 meter	15 cm
Focal length 19 mm	FOV 32° x 26°	0.895 mrad from 1 meter	20 cm
Resolution 336 x 256 pixels	Field of view	Spatial resolution	Min focus distance
Focal length 6.8 mm	FOV 45.6° x 35.5°	2.5 mrad from 1 meter	5 cm
Focal length 9 mm	FOV 35° x 27°	1.889 mrad from 1 meter	7 cm
Focal length 13 mm	FOV 25° x 19°	1.308 mrad from 1 meter	15 cm
Focal length 19 mm	FOV 17° x 13°	0.895 mrad from 1 meter	20 cm





## Mechanical drawings – Back Cover IP65

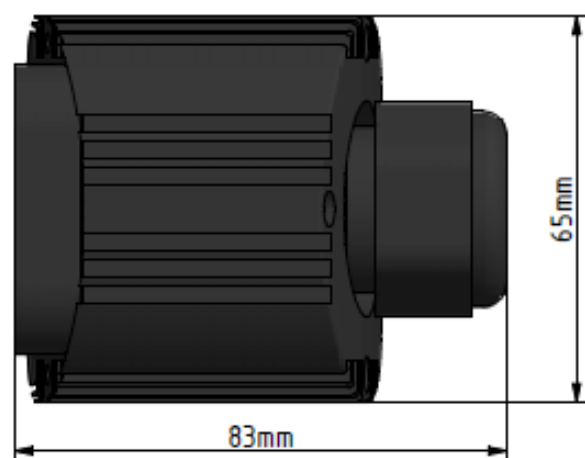
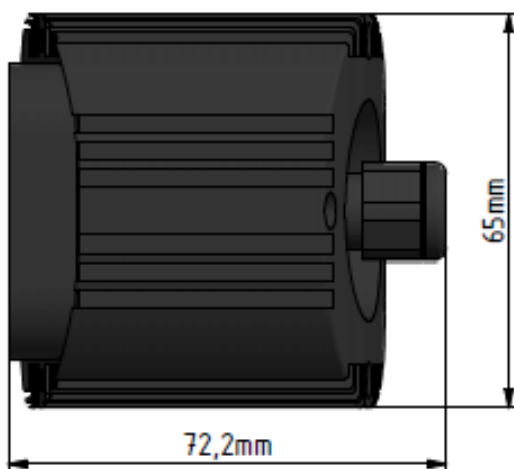
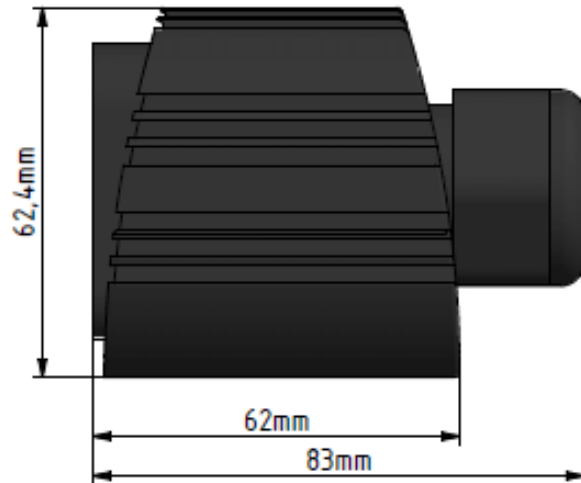
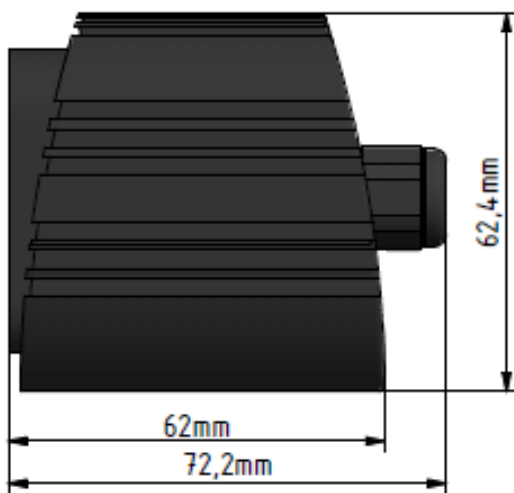
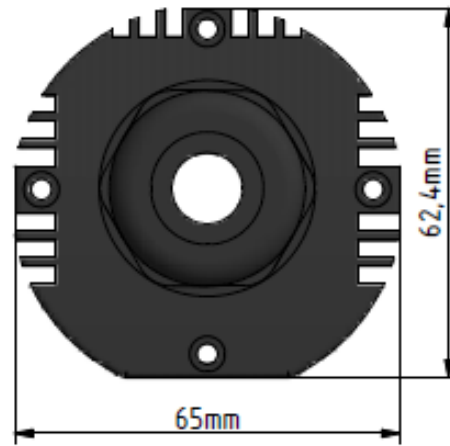
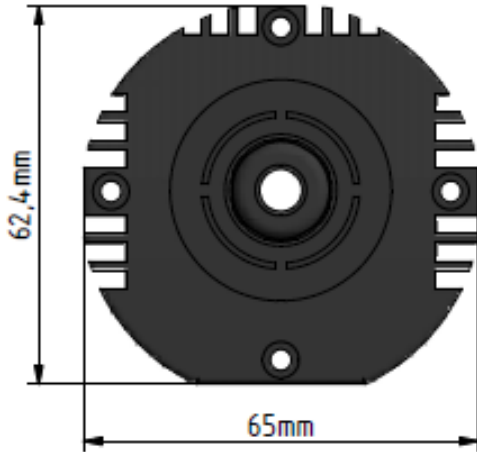

# Contact information

WORKSWELL IN THE WORLD



## Find our partners worldwide

[www.workswell.eu/where-to-buy](http://www.workswell.eu/where-to-buy)

### SALES DEPARTMENT

Website: [www.workswell.eu](http://www.workswell.eu)

E-mail: [sales@workswell.eu](mailto:sales@workswell.eu)

Mobile: +420 737 547 622

### COMPANY CONTACT

Website: [www.workswell.eu](http://www.workswell.eu)

E-mail: [info@workswell.eu](mailto:info@workswell.eu)

Mobile: +420 725 877 063

### OFFICE LOCATIONS

Europe - Prague

United States of America

Global partner network

[www.workswell.eu](http://www.workswell.eu)

